

# Permanent D-Bolt Anchorage Connectors

Models: 415, 416, 416SS, 417, 417SS, 418

## Description

Anchorage Connectors are designed as the intermediary for securing a connecting device to an anchorage. Careful consideration should be given to selecting a proper anchorage for ultimate safety. The anchorage should be easily accessible, located a safe distance above any lower obstacles and support 5,000 lbs (22kN) per worker.

## Technical

**Max. Working Load:** 400 lbs (181kg)

**Tensile Strength:** 5,000lbs (22kN)

## Certifications

Meets OSHA 1910.66, OSHA 1926.502(d), ANSI A10.32, and ANSI Z359.1 requirements.



## Materials

Model No.	Description	Material	Weight
415	D-bolt anchor with hardware (1/2" grade 8 bolt, lockwasher and nut); accommodates working thicknesses up to 3/4" (19mm)	Drop Forge Alloy Steel	1 lb. 5 oz (0.6kg)
416	D-bolt anchor with hardware (5/8" grade 8 bolt, lockwasher and nut); accommodates working thicknesses up to 4" (101.6mm)	Drop Forge Alloy Steel	1 lb. 8 oz (0.7kg)
416SS	D-bolt anchor with hardware (5/8" grade 8 bolt, lockwasher and nut); accommodates working thicknesses up to 4" (101.6mm)	Stainless Steel	1 lb. 8 oz (0.7kg)
417*	D-bolt anchor without hardware (Note: User supplies mounting hardware – 5/8" grade 8 bolt, lockwasher and nut.)	Drop Forge Alloy Steel	14.7 oz. (0.4kg)
417SS	D-bolt anchor without hardware (Note: User supplies mounting hardware – 5/8" grade 8 bolt, lockwasher and nut.)	Stainless Steel	14.7 oz. (0.4kg)
418	D-bolt anchor with hardware (3/4" grade 8 bolt, lockwasher and nut); accommodates working thicknesses up to 4" (101.6mm)	Drop Forge Alloy Steel	1 lb. 8 oz. (0.7kg)
419*	D-bolt anchor without hardware (Note: User supplies mounting hardware – 3/4" grade 8 bolt, lockwasher and nut.)	Drop Forge Alloy Steel	14.7 oz. (0.4kg)

\*Length of bolt may vary to accommodate different working thicknesses

# Permanent D-Bolt Anchorage Connectors

Models: 415, 416, 416SS, 417, 417SS, 418

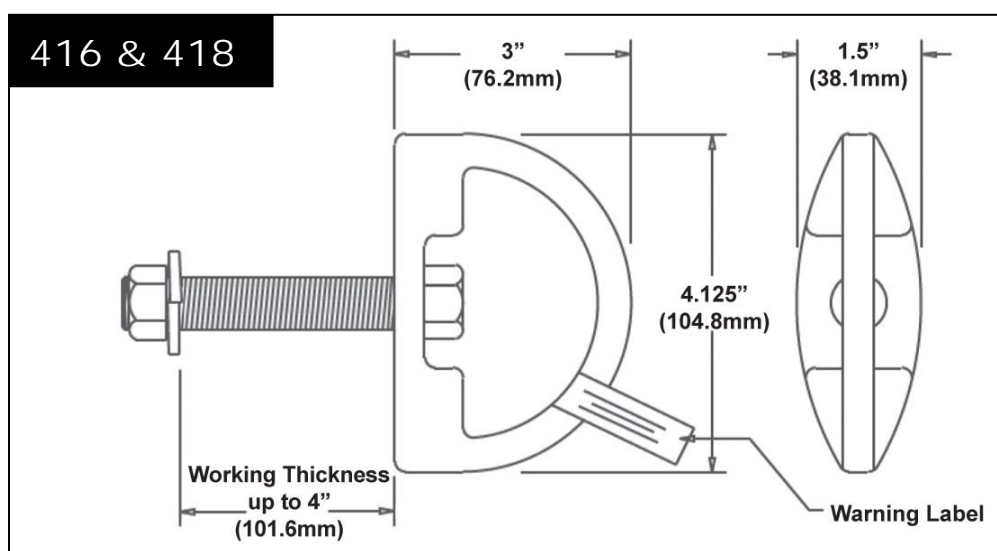
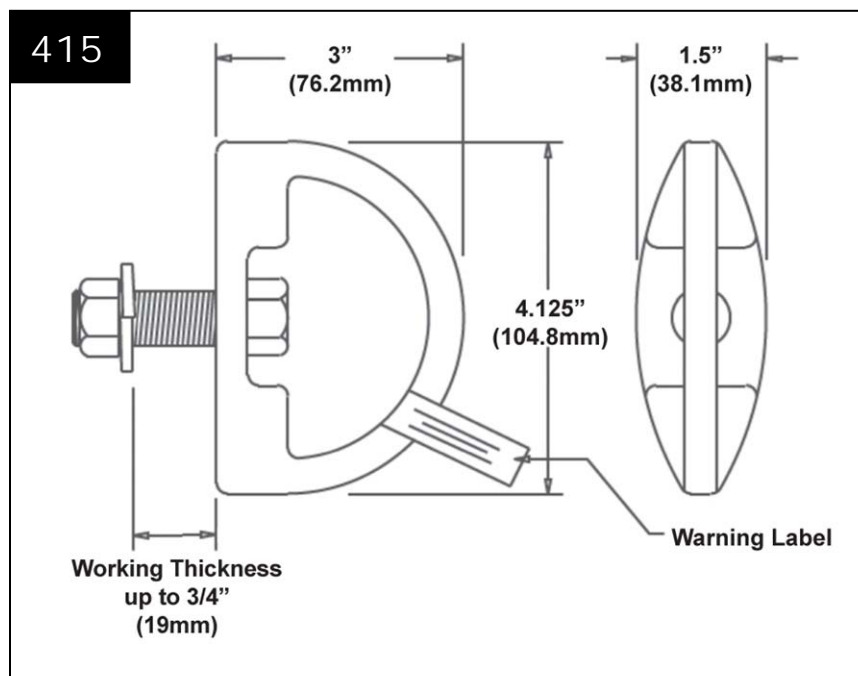

# MILLER®

by Honeywell

Toll Free 800.873.5242 • Phone 814.432.2118 • Fax 800.892.4078 • [www.millerfallprotection.com](http://www.millerfallprotection.com)

**▲ WARNING!** THIS DOCUMENT PROVIDES AN OVERVIEW OF FALL PROTECTION PRODUCTS AVAILABLE FROM HONEYWELL AND CARE HAS BEEN TAKEN TO ASSURE THE ACCURACY OF THE DATA. IT DOES NOT PROVIDE IMPORTANT PRODUCT WARNINGS AND INSTRUCTIONS. HONEYWELL RECOMMENDS ALL USERS OF FALL PROTECTION EQUIPMENT UNDERGO THOROUGH TRAINING, AND THAT ALL WARNINGS AND INSTRUCTIONS PROVIDED WITH THE PRODUCTS BE THOROUGHLY READ AND UNDERSTOOD PRIOR TO EACH USE. FAILURE TO READ AND FOLLOW ALL PRODUCT WARNINGS AND INSTRUCTIONS COULD RESULT IN SERIOUS INJURY OR DEATH.